

Protokoll fört vid enskild föredragning

Infrastrukturavdelningen
Transportbyrån, I2

Beslutande
Minister
Christian Wikström

Föredragande
Bitr. avdelningschef
Niklas Karlman

Justerat
Omedelbart

Nr 31

Upphandling second hand tonnage
ÅLR 2021/4962

Beslut

Beslöts publicera en inbjudan att anmäla intresse för upphandling av second hand tonnage enligt bilaga I221E27.

Upphandlingen genomförs i form av ett förhandlat förfarande och utförs enligt lag om offentlig upphandling (FFS 1397/2016), tillämplig på Åland genom landskapslag (2017:80) angående tillämpning i landskapet Åland av lagen om offentlig upphandling.

Fartygets totala uppskattade värde beräknas till 4 000 000 € exklusive moms. I värdet ingår fartyget inklusive eventuella anpassningar. Värdet på upphandlingen överstiger EU:s tröskelvärde om 214 000 €.

Upphandlingen annonseras på webbplatsen HILMA www.hankintailmoitukset.fi/sv/. Från HILMA skickas annonserna vidare för publicering till Europeiska unionens officiella tidning (S-serien) samt databasen TED. Upphandlingsdokumentet inklusive bilagor är tillgängligt elektroniskt på e-Avrop <https://www.e-avrop.com>.

Kostnaderna påförs anslag 975000, Fartygs- och färjeinvesteringar.





Motivering

Den upphandlande enheten har behov av ett fartyg som kommer att trafikera i Ålands skärgård. Landskapets tonnage är ålderstiget och har kapacitetsutmaningar och behöver förnyas av dessa orsaker.

Bakgrund

I den andra tilläggsbudgeten för år 2021 har beviljats en fullmakt för att införskaffa lämpligt begagnat tonnage för att förnya flottan.

KOORDINATSYSTEM
PLANSYSTEM ETRS-GK20
HÖJDSYSTEM N2000
TECKENFÖRKLARING

-  PIL FÖR VATTENAVRINNING
-  FASTIGHETSGRÄNS
-  ENTREPRENADGRÄNS
-  ASFALTSKANT
-  STÅNGSEL

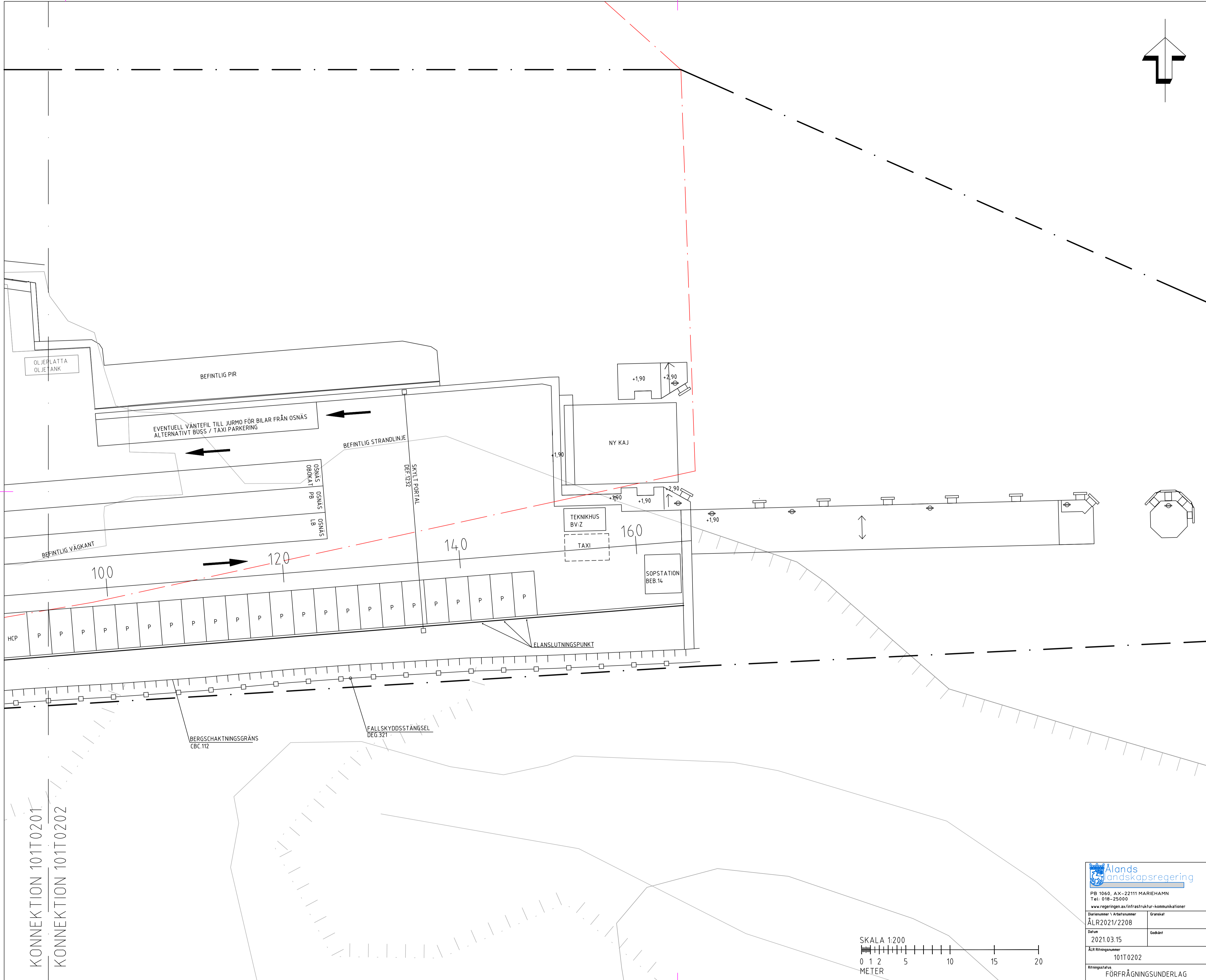
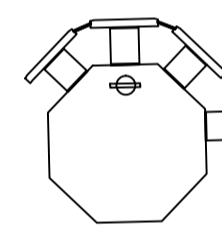
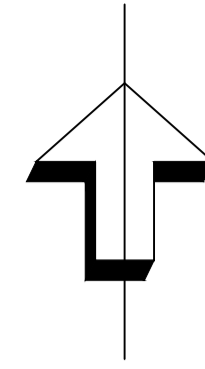

GRANSKNINGSHANDLING

BET	ÄNDRINGEN AVSER	DATUM	SIGN
-----	-----------------	-------	------

FÖRFRÅGNINGSUNDERLAG



DEAB Konsult
Karrböv. 16
ÅX-22150 Jomala
+358 405265467
www.deab.ax



Ålands landskapsregering
PB 1060, ÅX-22111 MARIEHAMN
Tel: 018-25000
www.regeringen.ax/infrastruktur-kommunikationer

Uppdragsnr: 15201
RITAD/KONSTRUERAD AV: LR
ANSVARIG: Dan Engblom
DATUM: 2021.03.15
ÅLR2021/2208
Datum: 2021.03.15
ÄLR Ritningsnummer: 101T0202
Ritningsstatus: FÖRFRÅGNINGSUNDERLAG

UPPDRAG NR 15201	RITAD/KONSTRUERAD AV LR	HANDLAGGARE Dan Engblom
DATUM 2021.03.15	ANSVARIG Dan Engblom	
ÅVA FÄRJFÄSTE Planritning Sektion 0/090 - 0/160		
SKALA 1:200	NUMMER A1	BET 101T0202
		REV

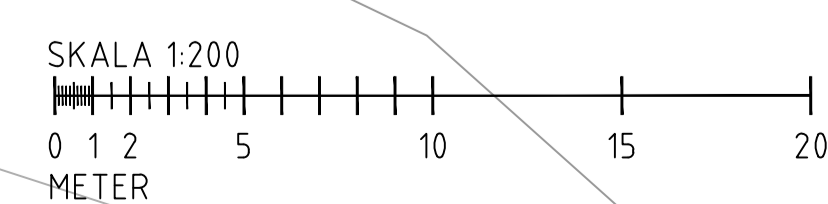

KONNEKTION 101T0201
KONNEKTION 101T0202

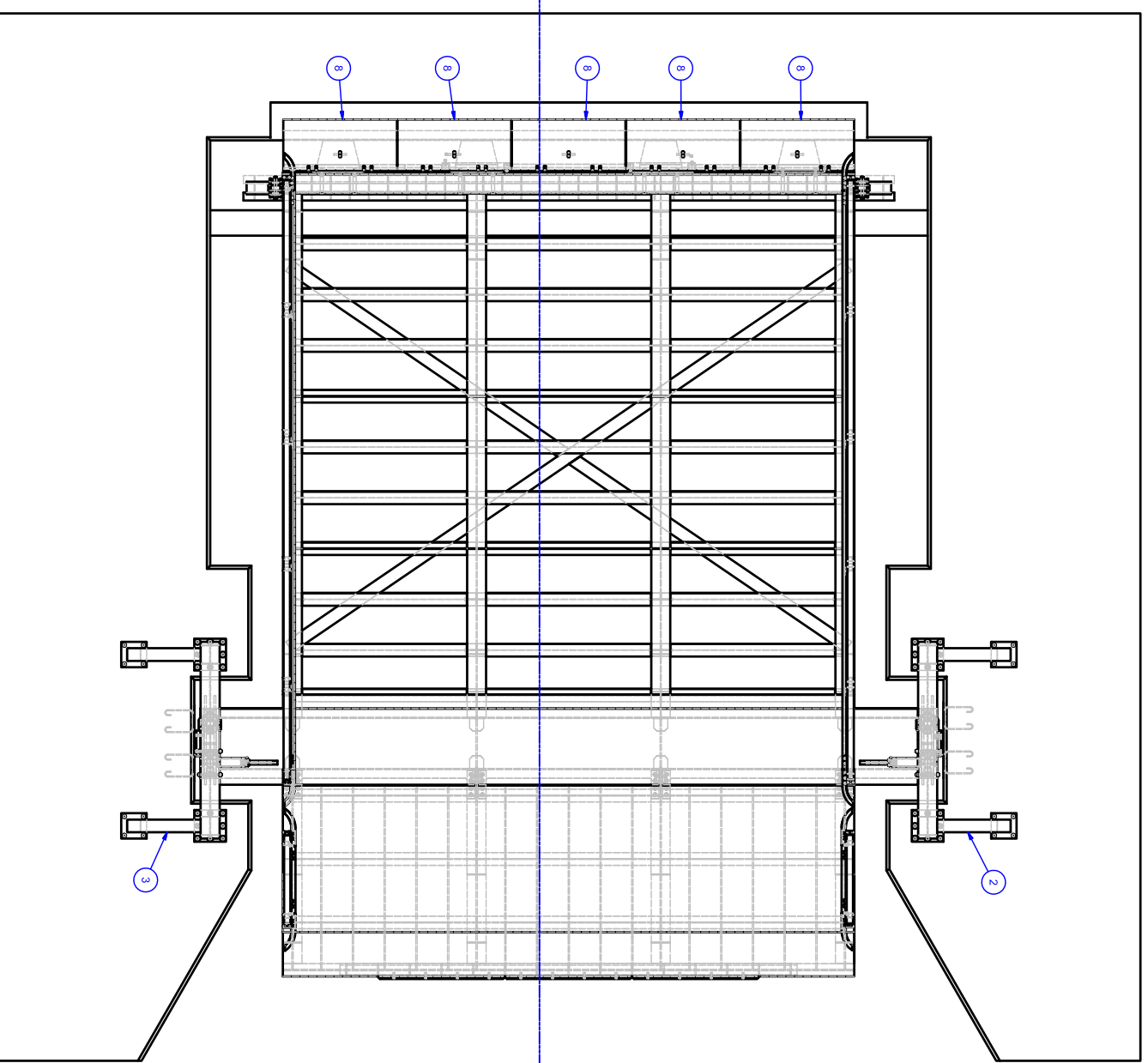
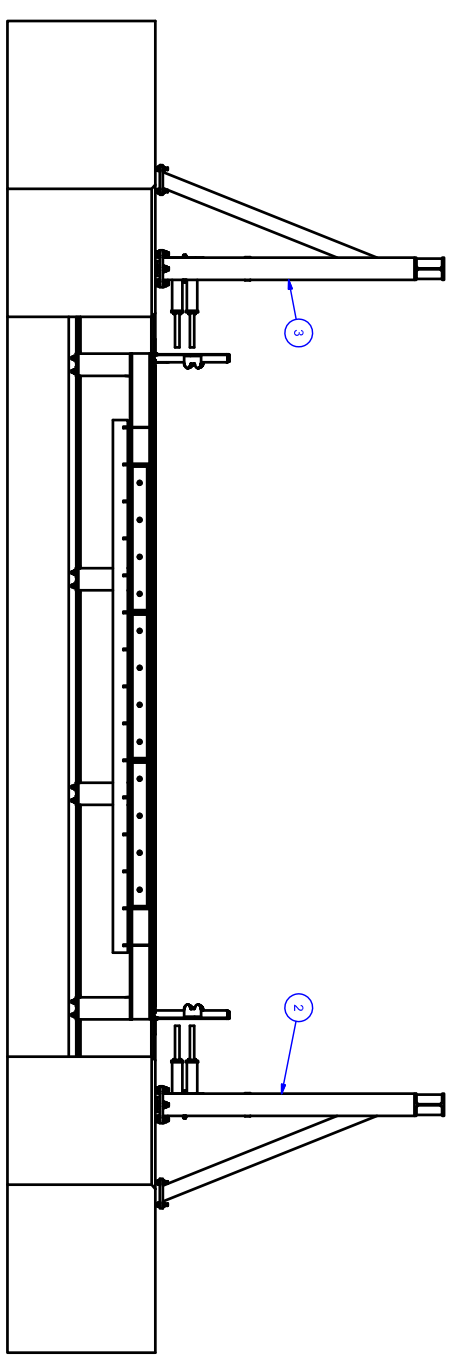
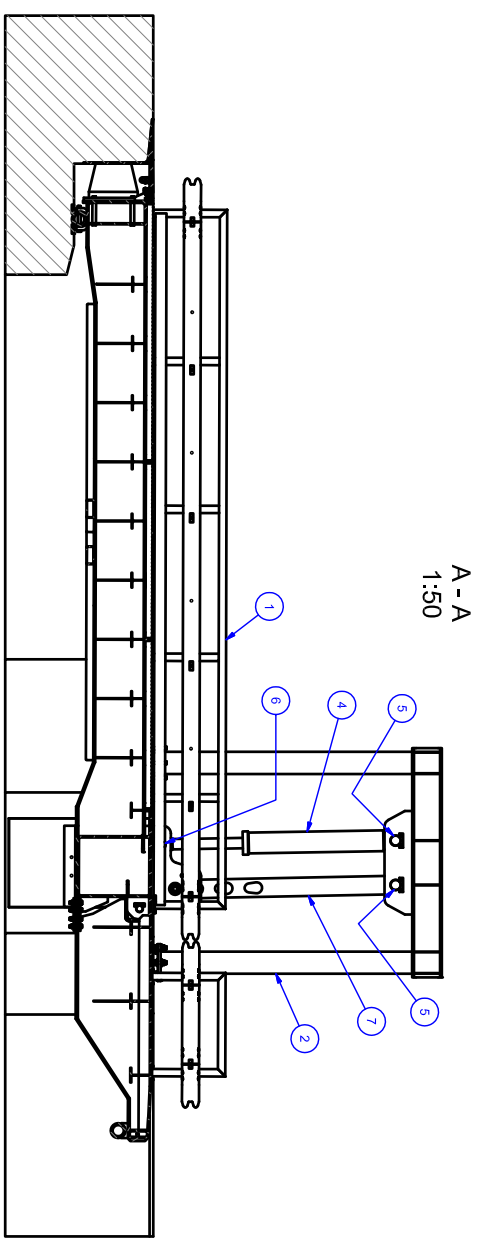

REV/DEL	BENÄMNING	RITN. NR.	MATERIAL	MATT. MODELL	VIKT / ST.	ST.
1	Ramp		PA6		482918 kg	1
2	Ljyttöm, vänster	103101 211			1671,3 kg	1
3	Ljyttöm, höger	103101 212			595,0 kg	2
4	Åxell	103101 212	ANSI 316	D140-230	5,4 kg	2
5	Låsstång	103101 212	SS5512	80x250x4000	520,7 kg	2
6	Åxell	103101 212	ANSI 316	D140-230	5,4 kg	2
7	Låsstång	103101 212	SS5512	80x250x4000	520,7 kg	2
8	Övergångsaxlar	103101 210			327,2 kg	5

FÖRFRÅGNINGSUNDERLAG



Eggenhetsgraden inom tekniken	Produktens namn	Skala
AVA FARJEFÄSTE	Huvudfröning	1:50
STÅLKLAFF	Rök front del	

Lohkosennus Oy
 FIN-201 2100 HÄLSÖNÄLVÄ
 FIN-02432 222
 FIN-02432 230

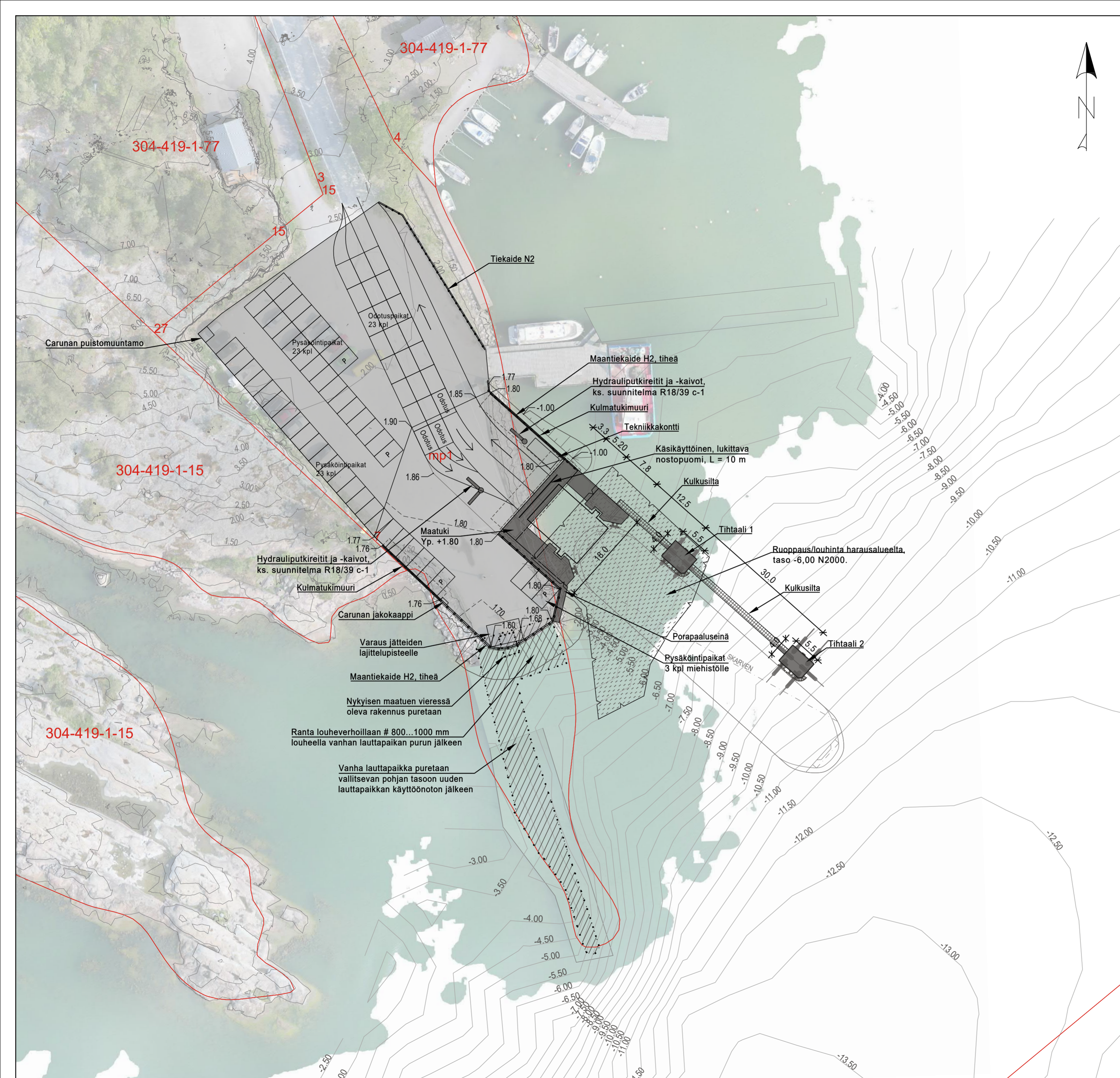
Datum	07.04.2021	Rev	IT	Code	TK
103101 220					



Selitteet:



-  Uudet rakenteet
-  Purettavat rakenteet
-  Liikennealue, päällyste uusitaan koko alueelta. Laajennuksien päällysrakenteet:

Päällyste	AB 16	50 mm
Profilointi	KaM #0...16 mm	50 mm
Kantava	KaM #0...55 mm	250 mm
Yht.		≥ 350 mm
-  Ruoppaus/louhinta

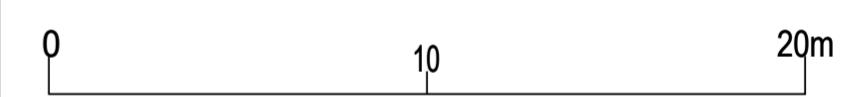
Työnaikaiset järjestelyt esitetty suunnitelmassa RE18/39 a-2



MERKKI	PVM	MUUTOS	TEHNYT	TARKASTANUT
HANKE VUOSNAISTEN AHVENANMAAN LIIKENTEEN LAUTTAPIAIKKA				
SILLAN NIMI JA KUNTA VUOSNAISTEN LAUTTARANTA, KUSTAVIN KUNTA				
TYYPPI ALUESUUNNITELMA				
JM VA	-		HL	-
KUORMA	LM1 NCCI 1-24/2017 / RIL201-3-2013		KORKEUS	-
KORKEUS-KOORDINAATTIJÄRJESTELMÄ		ETRS-GK21 - N2000	VINOUS	-

			
Taitorakenteiden suunnittelu		AFRY Finland Oy	
Varsinais-Suomen ELY-keskus			
SUUNN.	30.4.2020	M. Johansson	TARK./HYV.
TARK.	30.4.2020	J. Tuikka	Väylävirasto
HYVÄKS.	30.4.2020	H. Hekkala	TARK.
Geotekninen suunnittelu		AFRY Finland Oy	
		HYV.	
TARK.	30.4.2020	H. Hekkala	GEOHYV
MITTAK.		PIIR. NRO	
1:500		R18/39 a-1	

Preliminär teknisk specifikation

Den preliminära tekniska specifikationen kommer att utgöra en utgångspunkt för framtagandet av upphandlingsdokumenten (anbuds- och förhandlingsfasen). Eftersom den tekniska specifikationen är preliminär kan den komma att revideras och justeras i samband med att den publiceras i inbjudan att delta i förhandling och utgör således inte minimikrav.

1. Förhandlingsbara krav

Antal pax: 130-200st

Fartyget kan trafikeras med en besättning på 4-5 personer i åländska vatten

Fart: 11-14 knop

Passagerarsalong med sittplatser ovan bildäck

Fartyget har minst 4 besättningshytter för en 1 person/hytt, dusch och toalett i hytterna

Skall finnas möjlighet att laga mat ombord för besättningen.

Utrymme och utrustning för tvätt av personal kläder skall finnas.

Det finns minst en ute plats där passagerare kan vistas under resan

Fartyget skall överlämnas i nordisk hamn exkl. Island.

2. Utvärderingskriterier

Fartyget skall vara godkänt för drift med obemannat maskinrum (UMS)(E0)

På fartyget skall det finnas utrustning för inkoppling av landström

Fartyget skall vara anpassat att lastas och lossas med samverkande landklaffar/fästen

Anpassningar på fartyget så att det anpassas till befintlig hamnkonstruktion.

MEMORANDUM OF AGREEMENT

Norwegian Shipbrokers' Association's
Memorandum of Agreement for sale and
purchase of ships. Adopted by BIMCO in 1956.
Code-name
SALEFORM 2012
Revised 1966, 1983 and 1986/87, 1993 and 2012

Explanatory Notes for SALEFORM 2012 are available from BIMCO at www.bimco.org

Printed by BIMCO's idea

Copyright: Norwegian Shipbrokers' Association, Oslo.
Published by Norwegian Shipbrokers' Association, Oslo and BIMCO, Copenhagen

Dated: _____	1
_____ (Name of sellers), hereinafter called the "Sellers", have agreed to sell, and	2
_____ (Name of buyers), hereinafter called the "Buyers", have agreed to buy:	3
Name of vessel: _____	4
IMO Number: _____	5
Classification Society: _____	6
Class Notation: _____	7
Year of Build: _____ Builder/Yard: _____	8
Flag: _____ Place of Registration: _____ GT/NT: _____/_____	9
hereinafter called the "Vessel", on the following terms and conditions:	10
Definitions	11
"Banking Days" are days on which banks are open both in the country of the currency stipulated for the Purchase Price in <u>Clause 1</u> (Purchase Price) and in the place of closing stipulated in <u>Clause 8</u> (Documentation) and _____ (add additional jurisdictions as appropriate).	12 13 14
"Buyers' Nominated Flag State" means _____ (state flag state).	15
"Class" means the class notation referred to above.	16
"Classification Society" means the Society referred to above.	17
"Deposit" shall have the meaning given in <u>Clause 2</u> (Deposit)	18
"Deposit Holder" means _____ (state name and location of Deposit Holder) or, if left blank, the Sellers' Bank, which shall hold and release the Deposit in accordance with this Agreement.	19 20
"In writing" or "written" means a letter handed over from the Sellers to the Buyers or vice versa, a registered letter, e-mail or telefax.	21 22
"Parties" means the Sellers and the Buyers.	23
"Purchase Price" means the price for the Vessel as stated in <u>Clause 1</u> (Purchase Price).	24
"Sellers' Account" means _____ (state details of bank account) at the Sellers' Bank.	25
"Sellers' Bank" means _____ (state name of bank, branch and details) or, if left blank, the bank notified by the Sellers to the Buyers for receipt of the balance of the Purchase Price.	26 27
1. Purchase Price	28
The Purchase Price is _____ (state currency and amount both in words and figures).	29
2. Deposit	30
As security for the correct fulfilment of this Agreement the Buyers shall lodge a deposit of _____% (_____per cent) or, if left blank, 10% (ten per cent), of the Purchase Price (the "Deposit") in an interest bearing account for the Parties with the Deposit Holder within three (3) Banking Days after the date that:	31 32 33 34
(i) this Agreement has been signed by the Parties and exchanged in original or by e-mail or telefax; and	35 36
(ii) the Deposit Holder has confirmed in writing to the Parties that the account has been opened.	37 38
The Deposit shall be released in accordance with joint written instructions of the Parties.	39
Interest, if any, shall be credited to the Buyers. Any fee charged for holding and releasing the Deposit shall be borne equally by the Parties. The Parties shall provide to the Deposit Holder all necessary documentation to open and maintain the account without delay.	40 41 42

3. Payment	43
On delivery of the Vessel, but not later than three (3) Banking Days after the date that Notice of Readiness has been given in accordance with <u>Clause 5</u> (Time and place of delivery and notices):	44 45 46
(i) the Deposit shall be released to the Sellers; and	47
(ii) the balance of the Purchase Price and all other sums payable on delivery by the Buyers to the Sellers under this Agreement shall be paid in full free of bank charges to the Sellers' Account.	48 49 50
4. Inspection	51
(a)* The Buyers have inspected and accepted the Vessel's classification records. The Buyers have also inspected the Vessel at/in _____ (state place) on _____ (state date) and have accepted the Vessel following this inspection and the sale is outright and definite, subject only to the terms and conditions of this Agreement.	52 53 54 55
(b)* The Buyers shall have the right to inspect the Vessel's classification records and declare whether same are accepted or not within _____ (state date/period).	56 57
The Sellers shall make the Vessel available for inspection at/in _____ (state place/range) within _____ (state date/period).	58 59
The Buyers shall undertake the inspection without undue delay to the Vessel. Should the Buyers cause undue delay they shall compensate the Sellers for the losses thereby incurred.	60 61
The Buyers shall inspect the Vessel without opening up and without cost to the Sellers.	62
During the inspection, the Vessel's deck and engine log books shall be made available for examination by the Buyers.	63 64
The sale shall become outright and definite, subject only to the terms and conditions of this Agreement, provided that the Sellers receive written notice of acceptance of the Vessel from the Buyers within seventy-two (72) hours after completion of such inspection or after the date/last day of the period stated in <u>Line 59</u> , whichever is earlier.	65 66 67 68
Should the Buyers fail to undertake the inspection as scheduled and/or notice of acceptance of the Vessel's classification records and/or of the Vessel not be received by the Sellers as aforesaid, the Deposit together with interest earned, if any, shall be released immediately to the Buyers, whereafter this Agreement shall be null and void.	69 70 71 72
*4(a) and 4(b) are alternatives; delete whichever is not applicable. In the absence of deletions, alternative 4(a) shall apply.	73 74
5. Time and place of delivery and notices	75
(a) The Vessel shall be delivered and taken over safely afloat at a safe and accessible berth or anchorage at/in _____ (state place/range) in the Sellers' option.	76 77
Notice of Readiness shall not be tendered before: _____ (date)	78
Cancelling Date (see <u>Clauses 5(c), 6 (a)(i), 6 (a) (iii) and 14</u>): _____	79
(b) The Sellers shall keep the Buyers well informed of the Vessel's itinerary and shall provide the Buyers with twenty (20), ten (10), five (5) and three (3) days' notice of the date the Sellers intend to tender Notice of Readiness and of the intended place of delivery.	80 81 82
When the Vessel is at the place of delivery and physically ready for delivery in accordance with this Agreement, the Sellers shall give the Buyers a written Notice of Readiness for delivery.	83 84
(c) If the Sellers anticipate that, notwithstanding the exercise of due diligence by them, the Vessel will not be ready for delivery by the Cancelling Date they may notify the Buyers in writing stating the date when they anticipate that the Vessel will be ready for delivery and proposing a new Cancelling Date. Upon receipt of such notification the Buyers shall have the option of either cancelling this Agreement in accordance with <u>Clause 14</u> (Sellers' Default) within three (3) Banking Days of receipt of the notice or of accepting the new date as the new Cancelling Date. If the Buyers have not declared their option within three (3) Banking Days of receipt of the Sellers' notification or if the Buyers accept the new date, the date proposed in the Sellers' notification shall be deemed to be the new Cancelling Date and shall be substituted for the Cancelling Date stipulated in <u>line 79</u> .	85 86 87 88 89 90 91 92 93 94
If this Agreement is maintained with the new Cancelling Date all other terms and conditions hereof including those contained in <u>Clauses 5(b) and 5(d)</u> shall remain unaltered and in full	95 96

force and effect.	97
(d) Cancellation, failure to cancel or acceptance of the new Cancelling Date shall be entirely without prejudice to any claim for damages the Buyers may have under <u>Clause 14</u> (Sellers' Default) for the Vessel not being ready by the original Cancelling Date.	98 99 100
(e) Should the Vessel become an actual, constructive or compromised total loss before delivery the Deposit together with interest earned, if any, shall be released immediately to the Buyers whereafter this Agreement shall be null and void.	101 102 103
6. Divers Inspection / Drydocking	104
(a)*	105
(i) The Buyers shall have the option at their cost and expense to arrange for an underwater inspection by a diver approved by the Classification Society prior to the delivery of the Vessel. Such option shall be declared latest nine (9) days prior to the Vessel's intended date of readiness for delivery as notified by the Sellers pursuant to <u>Clause 5(b)</u> of this Agreement. The Sellers shall at their cost and expense make the Vessel available for such inspection. This inspection shall be carried out without undue delay and in the presence of a Classification Society surveyor arranged for by the Sellers and paid for by the Buyers. The Buyers' representative(s) shall have the right to be present at the diver's inspection as observer(s) only without interfering with the work or decisions of the Classification Society surveyor. The extent of the inspection and the conditions under which it is performed shall be to the satisfaction of the Classification Society. If the conditions at the place of delivery are unsuitable for such inspection, the Sellers shall at their cost and expense make the Vessel available at a suitable alternative place near to the delivery port, in which event the Cancelling Date shall be extended by the additional time required for such positioning and the subsequent re-positioning. The Sellers may not tender Notice of Readiness prior to completion of the underwater inspection.	106 107 108 109 110 111 112 113 114 115 116 117 118 119 120 121
(ii) If the rudder, propeller, bottom or other underwater parts below the deepest load line are found broken, damaged or defective so as to affect the Vessel's class, then (1) unless repairs can be carried out afloat to the satisfaction of the Classification Society, the Sellers shall arrange for the Vessel to be drydocked at their expense for inspection by the Classification Society of the Vessel's underwater parts below the deepest load line, the extent of the inspection being in accordance with the Classification Society's rules (2) such defects shall be made good by the Sellers at their cost and expense to the satisfaction of the Classification Society without condition/recommendation** and (3) the Sellers shall pay for the underwater inspection and the Classification Society's attendance.	122 123 124 125 126 127 128 129 130 131
Notwithstanding anything to the contrary in this Agreement, if the Classification Society do not require the aforementioned defects to be rectified before the next class drydocking survey, the Sellers shall be entitled to deliver the Vessel with these defects against a deduction from the Purchase Price of the estimated direct cost (of labour and materials) of carrying out the repairs to the satisfaction of the Classification Society, whereafter the Buyers shall have no further rights whatsoever in respect of the defects and/or repairs. The estimated direct cost of the repairs shall be the average of quotes for the repair work obtained from two reputable independent shipyards at or in the vicinity of the port of delivery, one to be obtained by each of the Parties within two (2) Banking Days from the date of the imposition of the condition/recommendation, unless the Parties agree otherwise. Should either of the Parties fail to obtain such a quote within the stipulated time then the quote duly obtained by the other Party shall be the sole basis for the estimate of the direct repair costs. The Sellers may not tender Notice of Readiness prior to such estimate having been established.	132 133 134 135 136 137 138 139 140 141 142 143 144 145
(iii) If the Vessel is to be drydocked pursuant to <u>Clause 6(a)(ii)</u> and no suitable dry-docking facilities are available at the port of delivery, the Sellers shall take the Vessel to a port where suitable drydocking facilities are available, whether within or outside the delivery range as per <u>Clause 5(a)</u> . Once drydocking has taken place the Sellers shall deliver the Vessel at a port within the delivery range as per <u>Clause 5(a)</u> which shall, for the purpose of this Clause, become the new port of delivery. In such event the Cancelling Date shall be extended by the additional time required for the drydocking and extra steaming, but limited to a maximum of fourteen (14) days.	146 147 148 149 150 151 152 153
(b)* The Sellers shall place the Vessel in drydock at the port of delivery for inspection by the Classification Society of the Vessel's underwater parts below the deepest load line, the extent of the inspection being in accordance with the Classification Society's rules. If the rudder, propeller, bottom or other underwater parts below the deepest load line are found broken, damaged or defective so as to affect the Vessel's class, such defects shall be made good at the	154 155 156 157 158

Sellers' cost and expense to the satisfaction of the Classification Society without condition/recommendation**. In such event the Sellers are also to pay for the costs and expenses in connection with putting the Vessel in and taking her out of drydock, including the drydock dues and the Classification Society's fees. The Sellers shall also pay for these costs and expenses if parts of the tailshaft system are condemned or found defective or broken so as to affect the Vessel's class. In all other cases, the Buyers shall pay the aforesaid costs and expenses, dues and fees.	159 160 161 162 163 164 165
(c) If the Vessel is drydocked pursuant to Clause 6 (a)(ii) or 6 (b) above:	166
(i) The Classification Society may require survey of the tailshaft system, the extent of the survey being to the satisfaction of the Classification surveyor. If such survey is not required by the Classification Society, the Buyers shall have the option to require the tailshaft to be drawn and surveyed by the Classification Society, the extent of the survey being in accordance with the Classification Society's rules for tailshaft survey and consistent with the current stage of the Vessel's survey cycle. The Buyers shall declare whether they require the tailshaft to be drawn and surveyed not later than by the completion of the inspection by the Classification Society. The drawing and refitting of the tailshaft shall be arranged by the Sellers. Should any parts of the tailshaft system be condemned or found defective so as to affect the Vessel's class, those parts shall be renewed or made good at the Sellers' cost and expense to the satisfaction of Classification Society without condition/recommendation**.	167 168 169 170 171 172 173 174 175 176 177 178
(ii) The costs and expenses relating to the survey of the tailshaft system shall be borne by the Buyers unless the Classification Society requires such survey to be carried out or if parts of the system are condemned or found defective or broken so as to affect the Vessel's class, in which case the Sellers shall pay these costs and expenses.	179 180 181 182
(iii) The Buyers' representative(s) shall have the right to be present in the drydock, as observer(s) only without interfering with the work or decisions of the Classification Society surveyor.	183 184 185
(iv) The Buyers shall have the right to have the underwater parts of the Vessel cleaned and painted at their risk, cost and expense without interfering with the Sellers' or the Classification Society surveyor's work, if any, and without affecting the Vessel's timely delivery. If, however, the Buyers' work in drydock is still in progress when the Sellers have completed the work which the Sellers are required to do, the additional docking time needed to complete the Buyers' work shall be for the Buyers' risk, cost and expense. In the event that the Buyers' work requires such additional time, the Sellers may upon completion of the Sellers' work tender Notice of Readiness for delivery whilst the Vessel is still in drydock and, notwithstanding Clause 5(a), the Buyers shall be obliged to take delivery in accordance with Clause 3 (Payment), whether the Vessel is in drydock or not.	186 187 188 189 190 191 192 193 194 195 196
*6 (a) and 6 (b) are alternatives; delete whichever is not applicable. In the absence of deletions, alternative 6 (a) shall apply.	197 198
**Notes or memoranda, if any, in the surveyor's report which are accepted by the Classification Society without condition/recommendation are not to be taken into account.	199 200
7. Spares, bunkers and other items	201
The Sellers shall deliver the Vessel to the Buyers with everything belonging to her on board and on shore. All spare parts and spare equipment including spare tail-end shaft(s) and/or spare propeller(s)/propeller blade(s), if any, belonging to the Vessel at the time of inspection used or unused, whether on board or not shall become the Buyers' property, but spares on order are excluded. Forwarding charges, if any, shall be for the Buyers' account. The Sellers are not required to replace spare parts including spare tail-end shaft(s) and spare propeller(s)/propeller blade(s) which are taken out of spare and used as replacement prior to delivery, but the replaced items shall be the property of the Buyers. Unused stores and provisions shall be included in the sale and be taken over by the Buyers without extra payment.	202 203 204 205 206 207 208 209 210
Library and forms exclusively for use in the Sellers' vessel(s) and captain's, officers' and crew's personal belongings including the slop chest are excluded from the sale without compensation, as well as the following additional items: _____(include list)	211 212 213
Items on board which are on hire or owned by third parties, listed as follows, are excluded from the sale without compensation: _____(include list)	214 215
Items on board at the time of inspection which are on hire or owned by third parties, not listed above, shall be replaced or procured by the Sellers prior to delivery at their cost and expense.	216 217

The Buyers shall take over remaining bunkers and unused lubricating and hydraulic oils and greases in storage tanks and unopened drums and pay either:	218 219
(a) *the actual net price (excluding barging expenses) as evidenced by invoices or vouchers; or	220
(b) *the current net market price (excluding barging expenses) at the port and date of delivery of the Vessel or, if unavailable, at the nearest bunkering port,	221 222
for the quantities taken over.	223
Payment under this Clause shall be made at the same time and place and in the same currency as the Purchase Price.	224 225
"inspection" in this <u>Clause 7</u> , shall mean the Buyers' inspection according to <u>Clause 4(a)</u> or <u>4(b)</u> (Inspection), if applicable. If the Vessel is taken over without inspection, the date of this Agreement shall be the relevant date.	226 227 228
<i>*(a) and (b) are alternatives, delete whichever is not applicable. In the absence of deletions alternative (a) shall apply.</i>	229 230
8. Documentation	231
The place of closing: _____	232
(a) In exchange for payment of the Purchase Price the Sellers shall provide the Buyers with the following delivery documents:	233 234
(i) Legal Bill(s) of Sale in a form recordable in the Buyers' Nominated Flag State, transferring title of the Vessel and stating that the Vessel is free from all mortgages, encumbrances and maritime liens or any other debts whatsoever, duly notarially attested and legalised or apostilled, as required by the Buyers' Nominated Flag State;	235 236 237 238
(ii) Evidence that all necessary corporate, shareholder and other action has been taken by the Sellers to authorise the execution, delivery and performance of this Agreement;	239 240
(iii) Power of Attorney of the Sellers appointing one or more representatives to act on behalf of the Sellers in the performance of this Agreement, duly notarially attested and legalised or apostilled (as appropriate);	241 242 243
(iv) Certificate or Transcript of Registry issued by the competent authorities of the flag state on the date of delivery evidencing the Sellers' ownership of the Vessel and that the Vessel is free from registered encumbrances and mortgages, to be faxed or e-mailed by such authority to the closing meeting with the original to be sent to the Buyers as soon as possible after delivery of the Vessel;	244 245 246 247 248
(v) Declaration of Class or (depending on the Classification Society) a Class Maintenance Certificate issued within three (3) Banking Days prior to delivery confirming that the Vessel is in Class free of condition/recommendation;	249 250 251
(vi) Certificate of Deletion of the Vessel from the Vessel's registry or other official evidence of deletion appropriate to the Vessel's registry at the time of delivery, or, in the event that the registry does not as a matter of practice issue such documentation immediately, a written undertaking by the Sellers to effect deletion from the Vessel's registry forthwith and provide a certificate or other official evidence of deletion to the Buyers promptly and latest within four (4) weeks after the Purchase Price has been paid and the Vessel has been delivered;	252 253 254 255 256 257 258
(vii) A copy of the Vessel's Continuous Synopsis Record certifying the date on which the Vessel ceased to be registered with the Vessel's registry, or, in the event that the registry does not as a matter of practice issue such certificate immediately, a written undertaking from the Sellers to provide the copy of this certificate promptly upon it being issued together with evidence of submission by the Sellers of a duly executed Form 2 stating the date on which the Vessel shall cease to be registered with the Vessel's registry;	259 260 261 262 263 264
(viii) Commercial Invoice for the Vessel;	265
(ix) Commercial Invoice(s) for bunkers, lubricating and hydraulic oils and greases;	266
(x) A copy of the Sellers' letter to their satellite communication provider cancelling the Vessel's communications contract which is to be sent immediately after delivery of the Vessel;	267 268 269
(xi) Any additional documents as may reasonably be required by the competent authorities of the Buyers' Nominated Flag State for the purpose of registering the Vessel, provided the Buyers notify the Sellers of any such documents as soon as possible after the date of	270 271 272

this Agreement; and	273
(xii) The Sellers' letter of confirmation that to the best of their knowledge, the Vessel is not black listed by any nation or international organisation.	274 275
(b) At the time of delivery the Buyers shall provide the Sellers with:	276
(i) Evidence that all necessary corporate, shareholder and other action has been taken by the Buyers to authorise the execution, delivery and performance of this Agreement; and	277 278
(ii) Power of Attorney of the Buyers appointing one or more representatives to act on behalf of the Buyers in the performance of this Agreement, duly notarially attested and legalised or apostilled (as appropriate).	279 280 281
(c) If any of the documents listed in Sub-clauses (a) and (b) above are not in the English language they shall be accompanied by an English translation by an authorised translator or certified by a lawyer qualified to practice in the country of the translated language.	282 283 284
(d) The Parties shall to the extent possible exchange copies, drafts or samples of the documents listed in Sub-clause (a) and Sub-clause (b) above for review and comment by the other party not later than _____ (state number of days), or if left blank, nine (9) days prior to the Vessel's intended date of readiness for delivery as notified by the Sellers pursuant to <u>Clause 5(b)</u> of this Agreement.	285 286 287 288 289
(e) Concurrent with the exchange of documents in Sub-clause (a) and Sub-clause (b) above, the Sellers shall also hand to the Buyers the classification certificate(s) as well as all plans, drawings and manuals, (excluding ISM/ISPS manuals), which are on board the Vessel. Other certificates which are on board the Vessel shall also be handed over to the Buyers unless the Sellers are required to retain same, in which case the Buyers have the right to take copies.	290 291 292 293 294
(f) Other technical documentation which may be in the Sellers' possession shall promptly after delivery be forwarded to the Buyers at their expense, if they so request. The Sellers may keep the Vessel's log books but the Buyers have the right to take copies of same.	295 296 297
(g) The Parties shall sign and deliver to each other a Protocol of Delivery and Acceptance confirming the date and time of delivery of the Vessel from the Sellers to the Buyers.	298 299
9. Encumbrances	300
The Sellers warrant that the Vessel, at the time of delivery, is free from all charters, encumbrances, mortgages and maritime liens or any other debts whatsoever, and is not subject to Port State or other administrative detentions. The Sellers hereby undertake to indemnify the Buyers against all consequences of claims made against the Vessel which have been incurred prior to the time of delivery.	301 302 303 304 305
10. Taxes, fees and expenses	306
Any taxes, fees and expenses in connection with the purchase and registration in the Buyers' Nominated Flag State shall be for the Buyers' account, whereas similar charges in connection with the closing of the Sellers' register shall be for the Sellers' account.	307 308 309
11. Condition on delivery	310
The Vessel with everything belonging to her shall be at the Sellers' risk and expense until she is delivered to the Buyers, but subject to the terms and conditions of this Agreement she shall be delivered and taken over as she was at the time of inspection, fair wear and tear excepted.	311 312 313
However, the Vessel shall be delivered free of cargo and free of stowaways with her Class maintained without condition/recommendation*, free of average damage affecting the Vessel's class, and with her classification certificates and national certificates, as well as all other certificates the Vessel had at the time of inspection, valid and unextended without condition/recommendation* by the Classification Society or the relevant authorities at the time of delivery.	314 315 316 317 318 319
"inspection" in this <u>Clause 11</u> , shall mean the Buyers' inspection according to <u>Clause 4(a)</u> or <u>4(b)</u> (Inspections), if applicable. If the Vessel is taken over without inspection, the date of this Agreement shall be the relevant date.	320 321 322
<i>*Notes and memoranda, if any, in the surveyor's report which are accepted by the Classification Society without condition/recommendation are not to be taken into account.</i>	323 324
12. Name/markings	325
Upon delivery the Buyers undertake to change the name of the Vessel and alter funnel markings.	326 327
13. Buyers' default	328

Should the Deposit not be lodged in accordance with <u>Clause 2</u> (Deposit), the Sellers have the right to cancel this Agreement, and they shall be entitled to claim compensation for their losses and for all expenses incurred together with interest.	329 330 331
Should the Purchase Price not be paid in accordance with <u>Clause 3</u> (Payment), the Sellers have the right to cancel this Agreement, in which case the Deposit together with interest earned, if any, shall be released to the Sellers. If the Deposit does not cover their loss, the Sellers shall be entitled to claim further compensation for their losses and for all expenses incurred together with interest.	332 333 334 335 336
14. Sellers' default	337
Should the Sellers fail to give Notice of Readiness in accordance with <u>Clause 5(b)</u> or fail to be ready to validly complete a legal transfer by the Cancelling Date the Buyers shall have the option of cancelling this Agreement. If after Notice of Readiness has been given but before the Buyers have taken delivery, the Vessel ceases to be physically ready for delivery and is not made physically ready again by the Cancelling Date and new Notice of Readiness given, the Buyers shall retain their option to cancel. In the event that the Buyers elect to cancel this Agreement, the Deposit together with interest earned, if any, shall be released to them immediately.	338 339 340 341 342 343 344 345
Should the Sellers fail to give Notice of Readiness by the Cancelling Date or fail to be ready to validly complete a legal transfer as aforesaid they shall make due compensation to the Buyers for their loss and for all expenses together with interest if their failure is due to proven negligence and whether or not the Buyers cancel this Agreement.	346 347 348 349
15. Buyers' representatives	350
After this Agreement has been signed by the Parties and the Deposit has been lodged, the Buyers have the right to place two (2) representatives on board the Vessel at their sole risk and expense.	351 352 353
These representatives are on board for the purpose of familiarisation and in the capacity of observers only, and they shall not interfere in any respect with the operation of the Vessel. The Buyers and the Buyers' representatives shall sign the Sellers' P&I Club's standard letter of indemnity prior to their embarkation.	354 355 356 357
16. Law and Arbitration	358
(a) *This Agreement shall be governed by and construed in accordance with English law and any dispute arising out of or in connection with this Agreement shall be referred to arbitration in London in accordance with the Arbitration Act 1996 or any statutory modification or re-enactment thereof save to the extent necessary to give effect to the provisions of this Clause.	359 360 361 362
The arbitration shall be conducted in accordance with the London Maritime Arbitrators Association (LMAA) Terms current at the time when the arbitration proceedings are commenced.	363 364 365
The reference shall be to three arbitrators. A party wishing to refer a dispute to arbitration shall appoint its arbitrator and send notice of such appointment in writing to the other party requiring the other party to appoint its own arbitrator within fourteen (14) calendar days of that notice and stating that it will appoint its arbitrator as sole arbitrator unless the other party appoints its own arbitrator and gives notice that it has done so within the fourteen (14) days specified. If the other party does not appoint its own arbitrator and give notice that it has done so within the fourteen (14) days specified, the party referring a dispute to arbitration may, without the requirement of any further prior notice to the other party, appoint its arbitrator as sole arbitrator and shall advise the other party accordingly. The award of a sole arbitrator shall be binding on both Parties as if the sole arbitrator had been appointed by agreement.	366 367 368 369 370 371 372 373 374 375
In cases where neither the claim nor any counterclaim exceeds the sum of US\$100,000 the arbitration shall be conducted in accordance with the LMAA Small Claims Procedure current at the time when the arbitration proceedings are commenced.	376 377 378
(b) *This Agreement shall be governed by and construed in accordance with Title 9 of the United States Code and the substantive law (not including the choice of law rules) of the State of New York and any dispute arising out of or in connection with this Agreement shall be referred to three (3) persons at New York, one to be appointed by each of the parties hereto, and the third by the two so chosen; their decision or that of any two of them shall be final, and for the purposes of enforcing any award, judgment may be entered on an award by any court of competent jurisdiction. The proceedings shall be conducted in accordance with the rules of the Society of Maritime Arbitrators, Inc.	379 380 381 382 383 384 385 386
In cases where neither the claim nor any counterclaim exceeds the sum of US\$ 100,000 the arbitration shall be conducted in accordance with the Shortened Arbitration Procedure of the	387 388

Society of Maritime Arbitrators, Inc. 389

(c) This Agreement shall be governed by and construed in accordance with the laws of _____ 390
(state place) and any dispute arising out of or in connection with this Agreement shall be 391
referred to arbitration at _____ (state place), subject to the procedures applicable there. 392

**16(a), 16(b) and 16(c) are alternatives; delete whichever is not applicable. In the absence of 393
deletions, alternative 16(a) shall apply. 394*

17. Notices 395

All notices to be provided under this Agreement shall be in writing. 396

Contact details for recipients of notices are as follows: 397

For the Buyers: _____ 398

For the Sellers: _____ 399

18. Entire Agreement 400

The written terms of this Agreement comprise the entire agreement between the Buyers and 401
the Sellers in relation to the sale and purchase of the Vessel and supersede all previous 402
agreements whether oral or written between the Parties in relation thereto. 403

Each of the Parties acknowledges that in entering into this Agreement it has not relied on and 404
shall have no right or remedy in respect of any statement, representation, assurance or 405
warranty (whether or not made negligently) other than as is expressly set out in this Agreement. 406

Any terms implied into this Agreement by any applicable statute or law are hereby excluded to 407
the extent that such exclusion can legally be made. Nothing in this Clause shall limit or exclude 408
any liability for fraud. 409

For and on behalf of the Sellers

For and on behalf of the Buyers

Name: _____

Name: _____

Title: _____

Title: _____

WORKING COPY